

# Thomson Electrak<sup>®</sup> MD Electric Linear Actuator

Installation Manual

Edition 2026-01



## Version history

<b>Edition</b>	<b>Reason for revision</b>
2020-02	First edition
2021-02	CANopen control option COO and EDS file link added
2024-10	Data for 48 Vdc supply voltage models added
2026-01	Updated front and back cover logotypes and layout

## Warranty

The Thomson Electrak<sup>®</sup> MD is warranted to be free from defects in materials and workmanship for a period of twelve (12) months from date of delivery. The application of this product is the responsibility of the buyer and Thomson makes no representation or warranty as to the suitability of the product for any particular use or purpose. For a copy of the entire warranty for this product that is contained in our standard terms and conditions of sale, please go to [www.thomsonlinear.com/en/support/terms-and-conditions](http://www.thomsonlinear.com/en/support/terms-and-conditions).

## Disclaimer

**Technical changes to improve the performance of the equipment may be made without prior notice!**

All rights reserved. No part of this work may be reproduced in any form (by printing, photocopying, microfilm or any other method) or processed, copied or distributed by electronic means without the written permission of Thomson.

Contents

**1. General ..... 4**

    1.1 About this manual ..... 4

    1.2 Target group ..... 4

    1.3 Symbols used ..... 4

    1.4 Transport and storage ..... 4

    1.5 Packaging ..... 4

    1.6 Disposal ..... 4

    1.7 Support ..... 4

**2. Safety ..... 5**

    2.1 Safety notes ..... 5

**3. Standards ..... 5**

    3.1 EC Declaration of conformity ..... 5

**4. Installation ..... 6**

    4.1 Product label ..... 6

    4.2 Terminology ..... 6

    4.3 Operation environment ..... 6

    4.4 Mechanical installation ..... 7

    4.5 Electrical installation ..... 10

    4.6 Control options installation and operation ..... 12

**5. CAN bus SAE J1939 information ..... 20**

    5.1 Introduction to CAN bus SAE J1939 ..... 20

    5.2 CAN bus SAE J1939 communications protocol ..... 20

**6. CAN bus CANopen information ..... 24**

    6.1 Introduction to CAN bus CANopen ..... 24

    6.2 Actuator control ..... 25

    6.3 Actuator feedback ..... 26

**7. Troubleshooting ..... 29**

    7.1 Troubleshooting ..... 29

**8. Technical specifications ..... 30**

    8.1 Technical data ..... 30

    8.2 Ordering key ..... 31

## 1. General

### 1.1 About this manual

This manual contains mechanical and electrical installation instructions for the Thomson Electrak® MD electric linear actuator. It also contains, among other things:

- technical data
- installation data
- type designation key.

It is important to carefully read this manual before installing the actuator and to have the correct qualifications needed to perform the installation.

### 1.2 Target group

This manual addresses qualified mechanical and electrical personnel.

### 1.3 Symbols used



This symbol is shown to highlight a general warning, general instruction or as a warning for a mechanical hazard.

### 1.4 Transport and storage

The actuator may only be transported and stored in the original packaging supplied by Thomson. The temperature during transportation and storage must be between -40 to +85° C (-40 to +185° F). Avoid shocks to the package. If the package is damaged, check the actuator for visible damage and notify the carrier, and if appropriate also Thomson.

### 1.5 Packaging

The packaging consists of a cardboard box. The box contains the actuator and this manual. For large quantity orders bulk packaging may be used in which case the packaging and the content will vary depending on the order agreement.

### 1.6 Disposal

Where required by law, used packaging and actuators are taken back by Thomson for professional disposal if the transportation cost is paid by the sender. Please contact Thomson for shipping information.

### 1.7 Support

If technical support or information is needed for this product, please contact the nearest Thomson Service Center. See the back of this manual. You can also visit [www.thomsonlinear.com](http://www.thomsonlinear.com) for information on this product and how to contact us.

## 2. Safety

### 2.1 Safety notes



- Only properly qualified personnel are permitted to perform mechanical and electrical installation of this product. Properly qualified personnel are familiar with mechanical or electrical installation work and have the appropriate qualifications for their job.
- Read this manual and any other available documentation before working on the equipment that the actuator is or shall be a part of.
- Conform strictly to the information contained in this manual and on the actuator product label on the actuator. Never exceed the performance limits stated herein.
- Never work on the actuator or its installation with the power on.
- Never unplug any cables or connectors during operation or with power on.
- Immediately stop using the actuator if it seems faulty or damaged in any way and notify an appropriate person so that corrective actions can be taken.
- Never open the actuator as that will compromise the sealing and the function of the actuator. There are no serviceable components inside.
- Grease may be present on the extension tube. Contact is non-hazardous. Film should not be removed.

## 3. Standards

### 3.1 EC Declaration of incorporation of partly completed machinery

We, Thomson Linear declare that this product corresponds with the International Standard ISO 13766:2006-05 2nd Edition (Earth Moving Machinery, Electromagnetic Compatibility). The directive (MD) 2006/42/EC annex 2.1.B, RoHS II directive 2011/65/EU, and that the standard EN ISO 12100:2010, Safety of machinery, have been applied.

**Thomson Electrak® MD Linear Actuator**  
.....  
Product

**MDxxAxxx-xxxxxxxxxxxxx**  
.....  
Description

Can be used when the machine or the system, which it shall be, a part of is in accordance with the demands in the EEC Machinery Directive and/or other relevant regulations.

**Kristianstad 2020-02-12**  
.....  
Date

**Håkan Persson**  
.....  
Name

**Business Unit Manager**  
.....  
Title

*Håkan Persson*  
.....  
Signature

## 4. Installation

### 4.1 Product label

The product label can be found on the side of the actuator. It will tell you which model of actuator you have, its basic performance data and where it is manufactured. Please study the product label to determine actuator type before starting any installation or service on the actuator. If you need any assistance from Thomson, please provide the serial number, manufacturing date and the designation of the actuator(s) in question. You can also use the QR code on the label to directly access Electrak MD information on [www.thomsonlinear.com](http://www.thomsonlinear.com).



### 4.2 Terminology

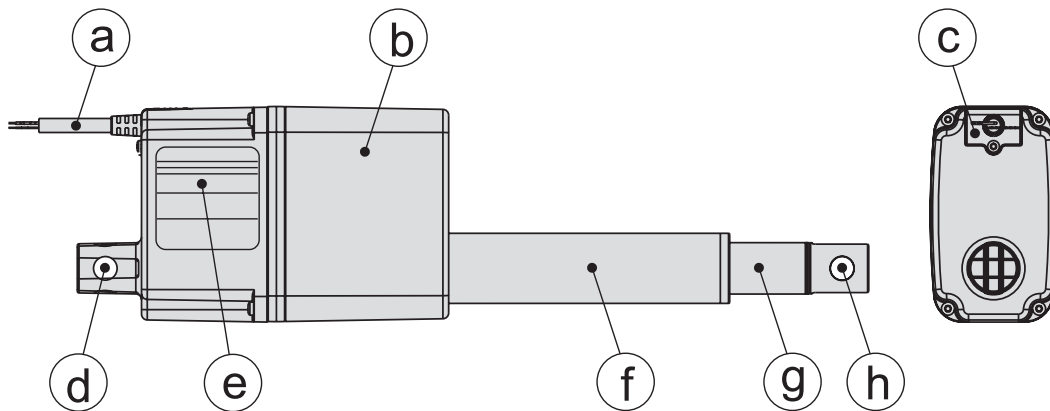

- |                   |                  |                                |
|-------------------|------------------|--------------------------------|
| a. power cable    | b. housing       | c. cable connector cover plate |
| d. rear adapter   | e. product label | f. cover tube                  |
| g. extension tube | h. front adapter |                                |

### 4.3 Operation environment



Min. -40° C (-40° F)



Max. +85° C (+185° F)



IP67 / IP69K

1. Operation temperature range is -40 to +85° Celsius (-40 to +185° Fahrenheit).
2. Protection degree against the ingress of water and particles is IP67 / IP69K.
3. Relative humidity range is 10 - 90 % non-condensing.

## 4.4 Mechanical installation

### 4.4.1 General installation safety notes



- Never work on the actuator with the power switched on!
- Do not hold the extension tube while the unit is energized.
- Failure modes of the actuator should be considered to ensure it does not create harm.

### 4.4.2 Basic installation considerations

1. Only mount the actuator using the holes in the rear (a) and front (b) adapters. Check the model number on the actuator product label (section 4.1) and then look at the ordering key (section 7.2) to find out your adapter type configuration.
2. Make sure that the actuator mounting position allows access to the cable connector cover plate (c), so that it can be removed to allow access to the cable connector (section 4.4.4).

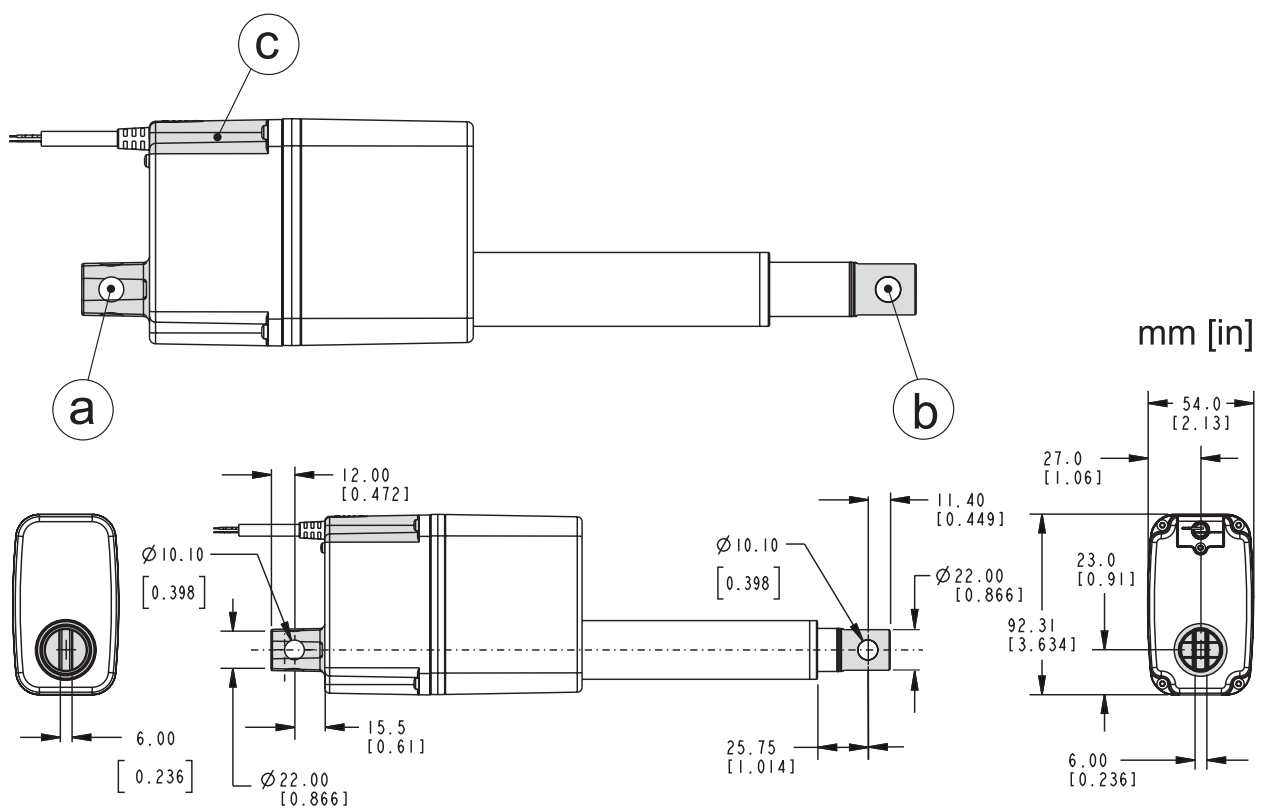

## 4.4.3 Mounting orientation and forces

1. The actuator can be mounted in any orientation and handle both pushing and pulling loads.
2. Always install actuator so that the force of the load acts in the center of the extension tube and the rear adapter.
3. Only mount the actuator to the rear and front adapter mounting holes.
4. Only use solid mounting pins and support them at both ends.
5. The mounting pins must be parallel to each other both radially and axially.

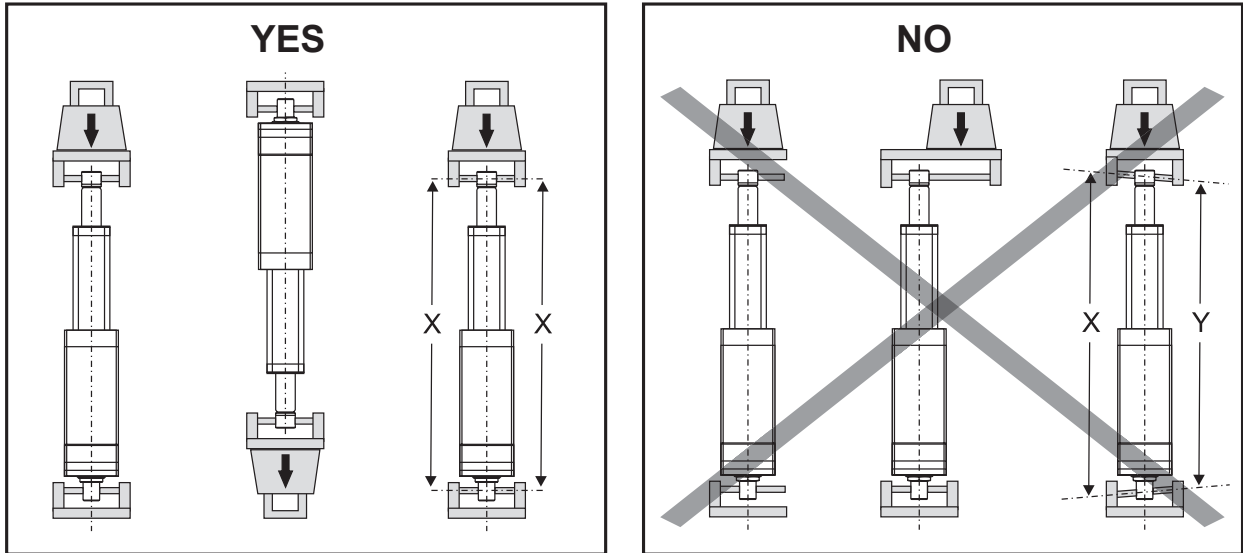

## 4.4.4 Cable connector cover plate

1. The cover plate is held in place by a screw (M2.5 with Torx T8 head) that can be accessed through the hole in the top of the cover plate (a). Keep in mind to mount the actuator so that there is enough clearance to access the screw with a tool!
2. Once the cover plate is released it needs to be pushed about 20 mm (0.8 inch) in the direction of the arrow symbol on the cover plate before it can be removed from the actuator (b). The connectors are a part of the backside of the cover plate and can be accessed once the cover plate is removed.
3. Make sure to put the cover plate back correctly and torque the screw to 0.45 Nm (4 in-lb) to ensure that the actuator cover plate and connectors are properly sealed.

## 4.5 Electrical installation

### 4.5.1 General notes



- Make sure the leads/cables leading to the motor can handle the maximum motor current.
- An emergency stop is recommended to reduce the chance of a crushing hazard.
- Never work on the actuator or the wiring with the power switched on!

### 4.5.2 Fuse size

Protect the actuator and the wiring by using a slow blow fuse between the actuator and the power source.

Recommended Fuse Size	
Actuator supply voltage	Fuse size
12 Vdc	10 A
24 Vdc	5 A
48 Vdc	2.5 A

### 4.5.3 Electrical connections

The actuator is supplied with a cable (a) to which all connections are done. The cable has flying leads in one end for customer connections. In the other end the cable is integrated into the cable connector cover plate (b) (section 4.4.4). The plug in connector allows replacing the actuator without disconnecting the flying leads.

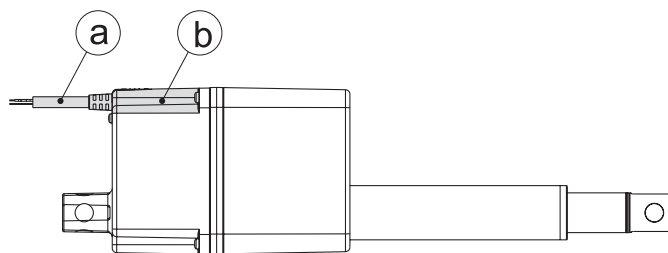

### 4.5.4 Lead cross sections

To avoid malfunction due to voltage drop the cross section of the leads between the actuator power leads and the power source must be of sufficient size. For longer cables than stated in the table, calculations based on the supply voltage, the current draw, the length of the cables and the ambient temperature must be done.

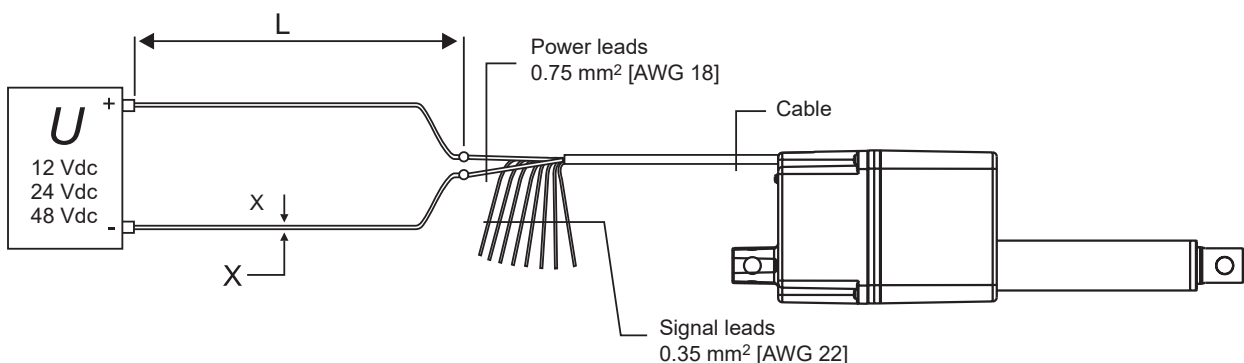

Power Lead Cross Sections	
Length of cable (L)	Min. allowed cross section (X)
0 - 3 m	1.5 mm² [AWG 16]
3 - 6 m	2.5 mm² [AWG 14]

## 4.5.5 Inrush current

At the start of the actuator there is an inrush current to the motor that will last between 75 to 150 milliseconds. See below table to determine the inrush current for the control option being used.

Control Option Inrush Current Level	
Option	Inrush current
EXX, ELX, EXP	up to 4 × rated current for the actuator model and load in question
XXX, XXP, LXX, LLX, LXP, LLP, CNO, COO	up to 2 × rated current for the actuator model and load in question



If using an AC powered power supply it must be sized to handle the inrush current (batteries typically have no problem delivering the inrush current). Also contacts, switches and relays must be sized appropriately to be able to handle the inrush current.

## 4.6 Control options installation and operation

### 4.6.1 General notes



- Avoid placing signal cables along power cables to reduce the risk of interference.
- Do not use vehicle earth as the return conductor. Instead use a two wire system to reduce the risk of interference.
- In very sensitive applications or where there is a risk of interference we recommend using shielded signal cables.
- Keep in mind that long cables in combination with small lead cross sections and low voltages may lead to undervoltage and malfunction due to voltage drop.
- Relays or other coil operated devices should have spark protection to avoid interference.
- Never work on the actuator or the wiring with the power switched on!

### 4.6.2 Speed control by adjusting the input voltage



Only Electrak MD actuators equipped with control option XXX or XXP can be speed controlled adjusting the input voltage (including by means of Pulse Width Modulation (PWM)). All other control options cannot. Instead, depending on type of control and voltage adjustment method attempted to use, the control will either keep the speed, stop or be permanently damaged and cause malfunction.

### 4.6.3 How to determine the control option

Electrak MD is equipped with one of the control options in the table below. To determine the option your actuator has, check the model number on the product label on the actuator (section 4.1) and then check the ordering key (section 7.2). Use the table below and go to the corresponding section for further information.

Control Options		
Option	Functions	Section
XXX	Internal End-of-Stroke Limit Switches	4.6.4
XXP	Internal End-of-Stroke Limit Switches + Analog Position Output	4.6.5
EXX	Electrak Monitoring Package	4.6.6
EXP	Electrak Monitoring Package + Analog Position Output	4.6.7
LXX	Electrak Monitoring Package + Low Level Signal Motor Switching	4.6.8
LLX	Electrak Monitoring Package + Low Level Signal Motor Switching + End of Stroke Indication Output	4.6.9
LXP	Electrak Monitoring Package + Low Level Signal Motor Switching + Analog Position Output	4.6.10
LLP	Electrak Monitoring Package + Low Level Signal Motor Switching + End of Stroke Indication Output + Analog Position Output	4.6.11
CNO	CAN Bus J1939 Control + Open Loop Speed Control	4.6.12
COO	CAN bus CANopen Control + Open Loop Speed Control	4.6.12

## 4.6.4 Control option XXX

Utilizing the internal control system the actuator will:

- Stop the actuator immediately at each end of mechanical travel.

To extend the actuator apply +Vdc to red and -Vdc to black. To retract apply -Vdc to red and +Vdc to black.

XXX Control Option Specifications		
Input voltage [Vdc]		
MD12		9 - 16
MD24		18 - 32
MD48		36 - 60
Max. actuator current draw [A]		see product label

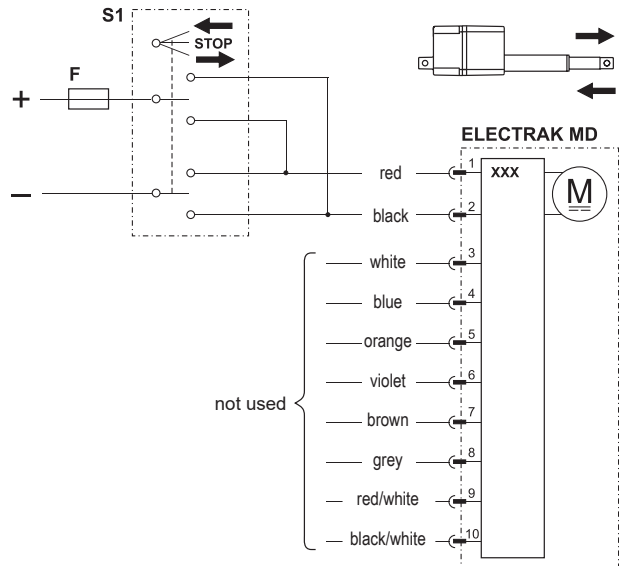

F Fuse

S1 Double pole double throw switch

## 4.6.5 Control option XXP

Control option XXP works as option XXX (section 4.6.4) but also has an analog (potentiometer) output that will provide feedback on the extension tube position.

To extend the actuator apply +Vdc to red and -Vdc to black. To retract apply -Vdc to black and +Vdc to red.

XXP Control Option Specifications		
Input voltage [Vdc]		
MD12		9 - 16
MD24		18 - 32
MD48		36 - 60
Max. actuator current draw [A]		see product label
Potentiometer type		wirewound
Potentiometer max. input voltage [Vdc]		32
Potentiometer max. power [W]		1
Potentiometer linearity [%]		± 0.25
Potentiometer output resolution [ohm/mm]		
MDxxA025, all strokes		16.67
MDxxA100, all strokes		16.67
MDxxA050, 50 - 250 mm stroke		33.33
MDxxA200, 50 - 250 mm stroke		33.33
MDxxA050, 300 mm stroke		16.67
MDxxA200, 300 mm stroke		16.67

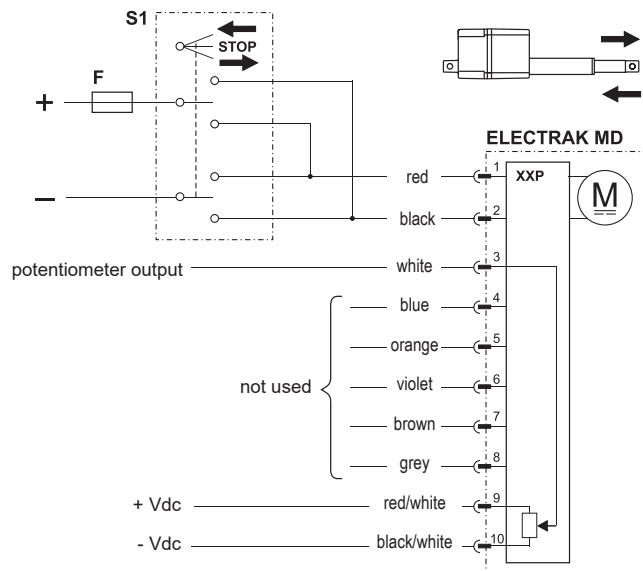

F Fuse

S1 Double pole double throw switch

### 4.6.6 Control option EXX

Utilizing the internal control system the actuator will:

- Stop the actuator immediately at each end of mechanical travel and throughout the stroke anytime current exceeds a factory preset value for the rated load (over load condition). This value is adjusted during operation automatically to provide consistent force. Resetting the actuator requires motion in opposite direction to continue normal operation.
- Stop the actuator when the current move is finished in the situation where voltage or temperature are outside their normal operating ranges. Once within the normal operating range the actuator will automatically reset and normal operation can be continued.



Always turn power off to the actuator before working on it to eliminate the risk of the actuator making unplanned moves after it has carried out the automatic reset.

To extend the actuator apply +Vdc to red and -Vdc to black. To retract apply -Vdc to red and +Vdc to black.

EXX Control Option Specifications		
Input voltage	[Vdc]	
MD12		9 - 16
MD24		18 - 32
Max. actuator current draw	[A]	see product label

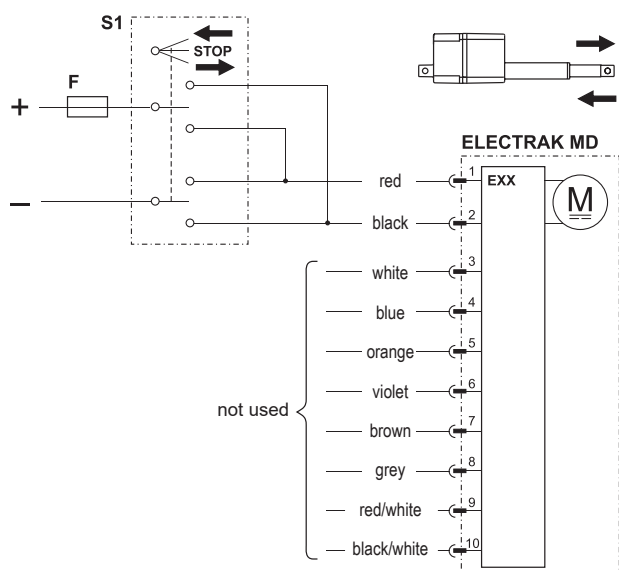

- F Fuse
- S1 Double pole double throw switch

## 4.6.7 Control option EXP

In addition to all of the features included in the EXX version (section 4.6.46, the EXP adds a potentiometer providing a voltage signal for the customer to use to determine position, speed and direction.

To extend the actuator apply +Vdc to red and -Vdc to black. To retract apply -Vdc to red and +Vdc to black.

EXP Control Option Specifications	
Input voltage [Vdc]	9 - 16 MD12 MD24
Max. actuator current draw [A]	see product label
Potentiometer type	wirewound
Potentiometer max. input voltage [Vdc]	32
Potentiometer max. power [W]	1
Potentiometer linearity [%]	± 0.25
Potentiometer output resolution [ohm/mm]	
MDxxA025, all strokes	16.67
MDxxA100, all strokes	16.67
MDxxA050, 50 - 250 mm stroke	33.33
MDxxA200, 50 - 250 mm stroke	33.33
MDxxA050, 300 mm stroke	16.67
MDxxA200, 300 mm stroke	16.67

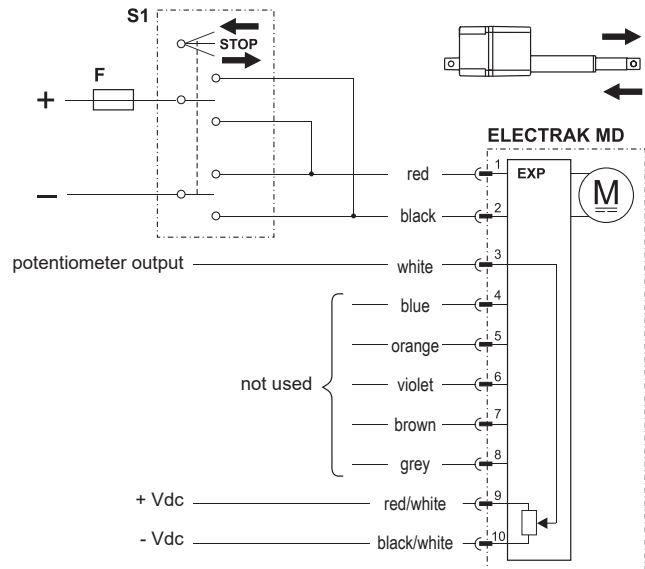

F Fuse

S1 Double pole double throw switch

### 4.6.8 Control option LXX

In addition to all of the features included in the EXX version (section 4.6.6), the LXX option allows the end user to extend, retract or stop the actuator using low current (<22 mA) input signals instead of switching the polarity of the input power voltage.

It also includes:

- An automatic soft start capability reducing the inrush current (section 4.5.5).
- A “sleep” mode function is activated when no motion is commanded for 15 seconds. In sleep mode the current draw is less than 1 mA for a 12 Vdc actuator, less the 2 mA for a 24 Vdc actuator and less the 4 mA for a 48 Vdc actuator. The sleep mode will exit and return to normal operation when the next move command is received.
- Dynamic braking throughout the entire stroke length whenever a motion command is removed.

Power the actuator by connecting red to + Vdc and black to - Vdc in the power cable. To extend the actuator apply +Vdc to violet and to retract apply +Vdc to orange in the signal cable while applying -Vdc to grey.

LXX Control Option Specifications		
Input voltage [Vdc]		
MD12		9 - 16
MD24		18 - 32
MD48		36 - 60
Max. actuator current draw [A]		see product label
Extend / retract input voltage [Vdc]		
MD12		9 - 32
MD24		9 - 32
MD48		9 - 60
Extend / retract input current [mA]		6 - 22

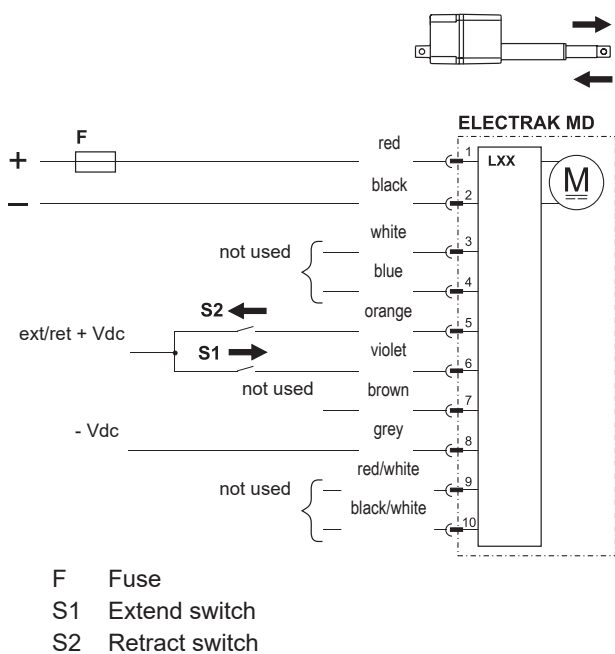

## 4.6.9 Control option LLX

In addition to all of the features included in the LXX version (section 4.6.8), LLX also includes end of stroke indication. These outputs can be used to provide feedback that the actuator has reached it's mechanical minimum or maximum stroke.

Since these outputs are current sinking open collector type of outputs, they will each require an external pull-up resistor to operate effectively.

Power the actuator by connecting red to + Vdc and black to - Vdc in the power cable. To extend the actuator apply +Vdc to violet and to retract apply +Vdc to orange in the signal cable while applying -Vdc to grey.

LLX Control Option Specifications	
Input voltage [Vdc]	
MD12	9 - 16
MD24	18 - 32
MD48	36 - 60
Max. actuator current draw [A]	see product label
Extend / retract input voltage [Vdc]	
MD12	9 - 32
MD24	9 - 32
MD48	9 - 60
Extend / retract input current [mA]	6 - 22
End-of-stroke output type	open collector
End-of-stroke output max. [Vdc] voltage	60
End-of-stroke output max. [mA] current	25

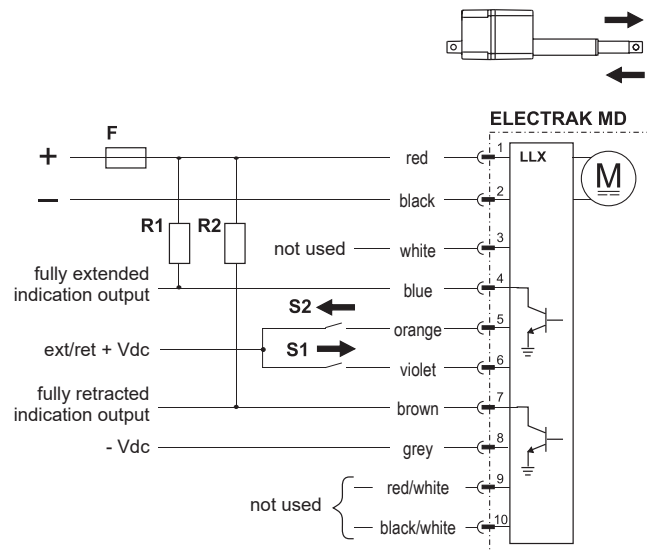

- F Fuse
- S1 Extend switch
- S2 Retract switch
- R1 Pull-up resistor
- R2 Pull-up resistor

#### 4.6.10 Control option LXP

In addition to all of the features included in the LXX version (section 4.6.8), LXP also includes a potentiometer providing a voltage signal for the customer to use to determine position, speed and direction.

Power the actuator by connecting red to + Vdc and black to - Vdc in the power cable. To extend the actuator apply +Vdc to violet and to retract apply +Vdc to orange in the signal cable while applying -Vdc to grey.

LXP Control Option Specifications		
Input voltage [Vdc]		
MD12		9 - 16
MD24		18 - 32
MD48		36 - 60
Max. actuator current draw [A]		see product label
Potentiometer type		wirewound
Potentiometer max. input voltage [Vdc]		32
Potentiometer max. power [W]		1
Potentiometer linearity [%]		± 0.25
Potentiometer output resolution [ohm/mm]		
MDxxA025, all strokes		16.67
MDxxA100, all strokes		16.67
MDxxA050, 50 - 250 mm stroke		33.33
MDxxA200, 50 - 250 mm stroke		33.33
MDxxA050, 300 mm stroke		16.67
MDxxA200, 300 mm stroke		16.67
Extend / retract input voltage [Vdc]		
MD12		9 - 32
MD24		9 - 32
MD48		9 - 60
Extend / retract input current [mA]		6 - 22

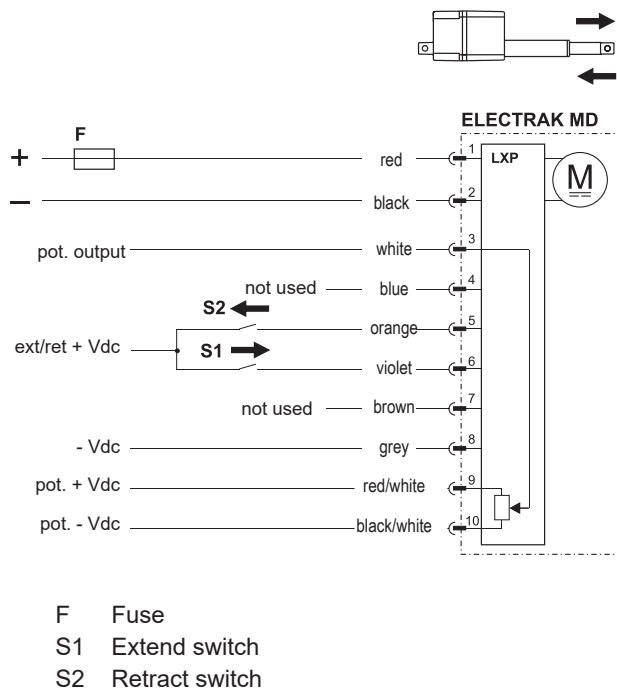

## 4.6.11 Control option LLP

In addition to all of the features included in the LLX version (section 4.6.9), LXP also includes a potentiometer providing a voltage signal for the customer to use to determine position, speed and direction.

The end-of-stroke indication outputs are current sinking open collector type of outputs, they will each require an external pull-up resistor to operate effectively.

Power the actuator by connecting red to + Vdc and black to - Vdc in the power cable. To extend the actuator apply +Vdc to violet and to retract apply +Vdc to orange in the signal cable while applying - Vdc to grey.

LLP Control Option Specifications	
Input voltage [Vdc]	
MD12	9 - 16
MD24	18 - 32
MD48	36 - 60
Max. actuator current draw [A]	see product label
Potentiometer type	wirewound
Potentiometer max. input voltage [Vdc]	32
Potentiometer max. power [W]	1
Potentiometer linearity [%]	± 0.25
Potentiometer output resolution [ohm/mm]	
MDxxA025, all strokes	16.67
MDxxA100, all strokes	16.67
MDxxA050, 50 - 250 mm stroke	33.33
MDxxA200, 50 - 250 mm stroke	33.33
MDxxA050, 300 mm stroke	16.67
MDxxA200, 300 mm stroke	16.67
Extend / retract input voltage [Vdc]	
MD12	9 - 32
MD24	9 - 32
MD48	9 - 60
Extend / retract input current [mA]	6 - 22
End-of-stroke output type	open collector
End-of-stroke output max. voltage [Vdc]	60
End-of-stroke output max. current [mA]	25

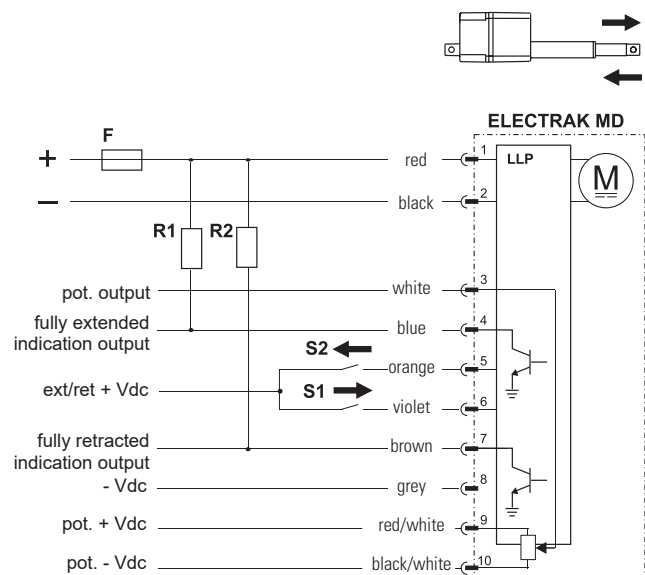

- F Fuse
- S1 Extend switch
- S2 Retract switch
- R1 Pull-up resistor
- R2 Pull-up resistor

4.6.12 Control option CNO and COO



This document assumes the user is familiar with the SAE J1939 and CANopen standards. Terminology from the standard is used, but not described in detail. See section 5 AND 6 for information on J1939 and CANopen operation and communication protocols, respectively.

4.6.12.1 General installation data

Voltage is to be directly connected to the actuator. All motion and protection on the CAN Bus option is handled through the CAN messages including overload protection. Please see section 5 and 6 for more details on the messages. The actuator can also be manually forced to extend by applying + Vdc to pin 6 (violet wire) and to retract by applying + Vdc to pin 5 (orange wire). When this is done the actuator will move with its maximum allowed settings.

CNO/COO Control Option Specifications	
Input voltage [Vdc]	9 - 16
MD12	18 - 32
MD24	36 - 60
Max. actuator current draw [A]	see product label
Forced extension / retraction input voltage [Vdc]	
MD12	9 - 32
MD24	9 - 32
MD48	9 - 60
Forced extension / retraction input current [mA]	6 - 22

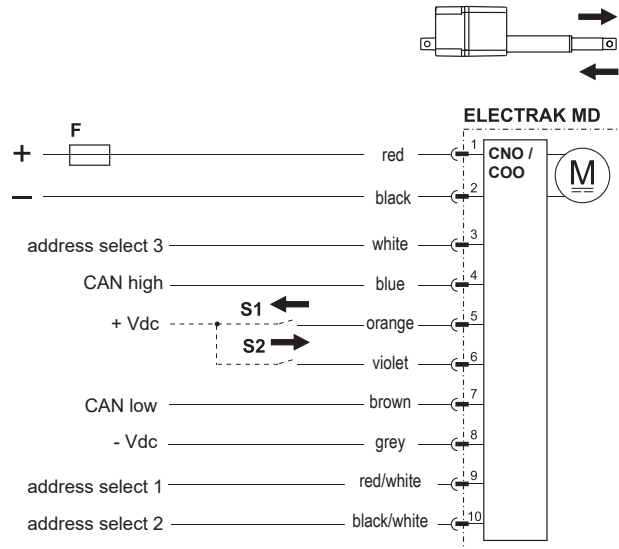

- F Fuse
- S1 Manual retraction switch (optional)
- S2 Manual extension switch (optional)

4.6.12.2 CANopen and CAN Bus SAE J1939 installation data

Follow wiring guidelines per ISO-11898 Standard CAN 2.0B, Protocol SAE J1939. Proper termination resistors (120 Ohm) should be placed in mating wire harness, see below. Please refer to section 5 for SAE J1939 communication details, and section 6 for CANopen communication details.

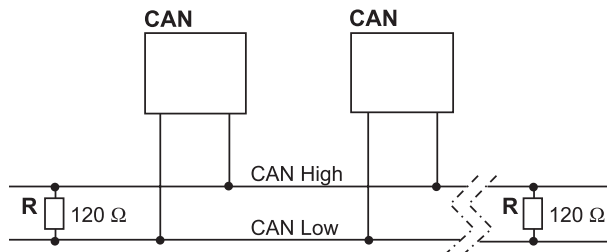

- CAN CAN Bus device in actuator or other equipment
- R Resistor

## 5. CAN Bus information

### 5.1 Introduction to CAN bus SAE J1939

This document assumes the reader is familiar with the SAE J1939 standard. Terminology from the standard is used, but not described in detail. The Electrak® MD actuator is compliant with the standard J1939, and supports the following PGNs (Parameter Group Number) from the standard.

J1939-21 – Data Link Layer

- Proprietary A 61184 (0x00EF00)
- Proprietary A2 126720 (0x01EF00)

J1939-81 – Network Management

- Address Claimed/Cannot Claim 60928 (0x00EE00)
- Commanded Address 65240 (0x00FED8)

### 5.2 CAN bus SAE J1939 communications protocol

#### 5.2.1 SAE J1939 NAME

The Electrak MD has the following defaults for the SAE J1939 NAME. Please refer to the SAE J1939/81 standard for more information on these parameters.

J1939 NAME Defaults	
Arbitrary Address Capable	Yes
Industry Group	0, Global
Vehicle System Instance	0
Vehicle System	0, Non-specific system
Function	255, Not available
ECU Instance	0, First instance
Manufacture Code	547, Thomson Linear LLC
Identity Number	1

#### 5.2.2 Address

The Electrak MD uses a default address value of 27 (0x1B). In applications where the default address is not available, there are three additional methods in choosing a new address.

1. The Electrak MD device is arbitrary address capable, if another device with a higher priority NAME contends for the selected address, the actuator will continue to request other addresses until it finds one that it can claim.
2. The Electrak MD device can also use the commanded address PGN to select a specified address. See SAE J1939/81 for more details about address claiming.
3. In some applications it may be more convenient to select an address through hardware switches. Activate the desired address select input by connecting it to positive and address select common to negative. This allows the user to change the default address using the address select inputs as defined in section 4.6.14. Activating individual select pins will create a binary adder to the default address. This method can allow up to 8 individual actuator addresses on a single bus. The below chart shows some examples on how this can be implemented. Note that conflicting messages produce arbitrary execution.

Address Select					
Address select common	Address select 3	Address select 2	Address select 1	Binary adder	Default address
Gnd	0	0	0	0	27 (0x1B)
Gnd	0	0	1	1	28 (0x1C)
Gnd	0	1	0	2	29 (0x1D)
...					
Gnd	1	1	1	7	34 (0x22)

### 5.2.3 Sleep operation

The Electrak MD utilizes a sleep mode operation when positioning is no longer required. This feature allows for a constant battery connection with minimal drain while the engine or vehicle is not running. After 5 seconds of bus inactivity, the actuator will put itself in a state of sleep. During this state the quiescent current is <1 mA for 12 Vdc models, <2 mA for 24 Vdc models and <4 mA for 48 Vdc models. When bus activity is restored the actuator will begin a wake up phase, followed by an address claim request.

### 5.2.4 SAE J1939 actuator control message (ACM)

All actuator control parameters are adjustable through the proprietary A message (PGN 61184). The preferred transmission repetition rate is 100ms (can also be sent as required by the application). Additional message specific information can be found in the table below, all other Proprietary A information can be found in the SAE J1939/21 specification.

Actuator Control Message Signal Information		
Start position	Length	Parameter name
1.1	14 bits	Position command
2.7	9 bits	Current limit
3.8	5 bits	Speed command
4.5	1 bit	Motion enable
4.6	35 bits	Factory use

The least significant bit of each message is indicated by the start position column

#### 5.2.4.1 Position command

This 14-bit signal is used to set the target position for the next actuator motion. Although resolution of the signal is represented as 0.1 mm/bit, true positional accuracy will be dependent on the stroke length of the given model. The actuator uses an internally calculated deadband value to determine when within a target position range. The 0.0 mm and full extend stroke values represent 0 to 100% stroke and are only relative to the actual available stroke of the individual unit.

Range: 0.0 mm to 300.0 mm  
Resolution: 0.1 mm/bit, 0 offset

#### 5.2.4.2 Current limit

This 9-bit signal is used to set a current at which the actuator will cease motion. In the event a force is applied to the actuator that causes the motor current to exceed this settable value for more than 50 ms, the actuator will stop any current motion and activate a dynamic braking effect on the motor. This current limit does not apply during the motor starting phase where in rush current can be significantly higher than normal running.

Range: 0.0 A to 8.0 A (12 Vdc actuator), 0.0 A to 4.0 A (24 Vdc actuator), 0.0 A to 2.0 A (48 Vdc actuator)  
Resolution: 0.1 A/bit, 0 offset

#### 5.2.4.3 Speed command

This 5-bit signal is used to set the speed of the actuator. The signal adjusts the PWM driver within the actuator and the voltage applied to the motor. The resultant actuator speed will be a ratio of the actuators max speed and also dependent on the load applied to the actuator.

Range: 20% to 100% motor duty cycle  
Note: The PWM driver will not provide enough voltage for the motor to operate properly below 20% utilization, therefore, 20% should be considered a lower limit for speed control.  
Resolution: 5%/bit, 0 offset

#### 5.2.4.4 Motion enable

This 1-bit signal is used to enable motion from the actuator. If this bit is low (0), no motion will be allowed. This signal can be used to define the next actuator movement message without starting the motor. When movement is required this bit can be changed to high (1) and motion will begin using the other parameter signals encoded in the ACM.

## 5.2.4.5 Factory use

The remaining 35 bits of the ACM are used for factory calibration use only and should be filled with 0x00 or 0xFF when sending this message.

## 5.2.5 SAE J1939 actuator feedback message (AFM)

All actuator feedback data can be retrieved through the proprietary A2 message (PGN 126720). This message is transmitted every 100ms. Additional message specific information can be found in Table 2, all other Proprietary A2 information can be found in the SAE J1939/21 specification.

Actuator Feedback Message Signal Information		
Start position	Length	Parameter name
1.1	14 bits	Measured position
2.7	9 bits	Measured current
3.8	5 bits	Running speed
4.5	2 bits	Voltage error
4.7	2 bits	Temperature error
5.1	1 bit	Motion flag
5.2	1 bit	Overload flag
5.3	1 bit	Backdrive flag
5.4	1 bit	Parameter flag
5.5	1 bit	Saturation flag
5.6	1 bit	Fatal error flag
5.7	26 bits	Factory use

The least significant bit of each message is indicated by the start position column

### 5.2.5.1 Measured position

This 14-bit signal is used to inform the user of the actual actuator stroke position. Although resolution of the signal is represented as 0.1 mm/bit, true positional accuracy will be dependent on the stroke length of the given model. The actuator uses an internally calculated deadband value to determine when it is within a target position range. The 0.0 mm and ordered full extend stroke values represent 0 to 100% stroke but the signaled value does not take in to account any mechanical tolerances or play in the actuator.

Range: 0.0 mm to 300.0 mm

Resolution: 0.1 mm/bit, 0 offset

### 5.2.5.2 Measured current

This 9-bit signal is used to inform the user of the actual current being drawn used by the actuator.

Range: 0.0 A to 20.0 A

Resolution: 0.1 A/bit, 0 offset

### 5.2.5.3 Running speed

This 5-bit signal is used to inform the user of the actual duty cycle being applied to the motor through the internal actuator controller.

Range: 0% to 100% motor duty cycle

Resolution: 5%/bit, 0 offset

### 5.2.5.4 Voltage error

This 2-bit signal is used to inform the user that the operational voltage is outside of allowable running parameters. Any motion already in progress will continue until completed, but additional movement request will not be allowed until the operational voltage returns within the normal operating range.

Voltage Error Message	
00	Input voltage within operational range
01	Input voltage below operational range
10	Input voltage above operational range
11	Not used

#### 5.2.5.5 Temperature error

This 2-bit signal is used to inform the user that the operational temperature is outside of allowable running parameters. Any motion already in progress will continue until completed, but additional movement request will not be allowed until the operational temperature returns within the normal operating range.

Temperature Error Message	
00	Temperature within operational range
01	Temperature below operational range
10	Temperature above operational range
11	Not used

#### 5.2.5.6 Motion flag

This 1-bit signal is used to inform the user that the actuator is currently in motion.

#### 5.2.5.7 Overload flag

This 1-bit signal is used to inform the user that the last motion the actuator attempted caused an overload condition. This occurs when the actuator determines the current set in the Current Limit signal from the ACM is exceeded for a consecutive 50 ms. When this flag is set by the actuator the user must reset the Motion Enable flag in the ACM before attempting additional motion from the actuator.

#### 5.2.5.8 Backdrive flag

This 1-bit signal is used to inform the user that the actuator has determined positional movement in the extension tube that was not commanded from the user. This can be caused from excessive static load or vibration being applied to the actuator.

#### 5.2.5.9 Parameter flag

This 1-bit signal is used to inform the user that one of the parameter signals in the ACM is outside the allowed parameters the specific model will allow. To prevent damage to the actuator motion is not allowed after this flag is set.

#### 5.2.5.10 Saturation flag

This 1-bit signal is used to inform the user that the actuator is currently running within 10% of its maximum capability. Additional speed or current needed from the application may not be able to be obtained with the chosen actuator model.

#### 5.2.5.11 Fatal error flag

This 1-bit signal is used to inform the user that the actuator needs service. If this flag is set power can be reset to determine if the flag is resettable, but it is suggested to contact the factory for additional support. To prevent possible additional damage motion is prohibited while this flag is set.

#### 5.2.5.12 Factory use

The remaining 26 bits of the Actuator Feedback Message are used for factory calibration use only and under normal operation will be returned with 0x00.

## 6. CAN bus CANopen information

### 6.1 Introduction to CANopen

#### 6.1.1 CANopen standard

This document assumes the reader is familiar with the CiA 301 specification released by CAN in Automation. Terminology from the standard is used, but not described in detail. The Electrak® MD actuator is compliant with the standard. The default baudrate is 500kbit/s and it will only support the standard CAN frame with 11-bit identifier field.

#### 6.1.2 EDS file

Thomson provides an electronic data sheet file (EDS) to integrate the Electrak MD into a specific CANopen network. The EDS file can be downloaded at [www.thomsonlinear.com/en/support/docs-linear-actuators-literature](http://www.thomsonlinear.com/en/support/docs-linear-actuators-literature) under the Configuration Files section.

#### 6.1.3 Node ID

The Electrak MD uses a default node ID of 27 (0x1B). In applications where the default address is not available, it is possible to select an address through hardware switches. Activate the desired address select input by connecting it to positive and address select common to negative. This allows the user to change the default address using the address select inputs as defined in section (CANopen connection diagram). Activating individual select pins will create a binary adder to the default address. This method can allow up to 8 individual actuator addresses on a single bus. The below chart shows some examples on how this can be implemented.

Address Select					
Address select common	Address select 3	Address select 2	Address select 1	Binary adder	Default address
Gnd	0	0	0	0	27 (0x1B)
Gnd	0	0	1	1	28 (0x1C)
Gnd	0	1	0	2	29 (0x1D)
...					
Gnd	1	1	1	7	34 (0x22)

#### 6.1.4 NMT State

The Electrak MD support the CANopen network management (NMT) slave state machine. It needs to be put in the operational state before operating properly.

##### Example

Sending a CAN message with id 0x0, containing the data 0x01 0x00 will put all connected actuators in the operational state. Sending a CAN message with id 0x0, containing the data 0x01 0x1B will put an actuator with the default Node ID in the operational state.

Ensure that the proper node ID is used when referencing multiple actuators on a single bus network.

#### 6.1.5 Sleep operation

The Electrak MD utilizes a sleep mode operation when positioning is no longer required. This feature allows for a constant battery connection with minimal drain while the engine or vehicle is not running. After 120 seconds of bus inactivity, the actuator will put itself in a state of sleep. During this state the quiescent current is <1 mA for 12 Vdc models, <2 mA for 24 Vdc models and <4 mA for 48 Vdc models. The actuator will leave the sleep mode when bus activity is restored.

## 6.2 Actuator control

### 6.2.1 Control PDO properties

Operational control of the actuator is achieved by sending the statically mapped RPDO with COB-ID 0x200 + Node ID. It will have the following layout:

Byte 0	Byte 1	Byte 2	Byte 3	Byte 4	Byte 5	Byte 6	Byte 7
Target Position		Current Limit		Target Speed		Movement Profile	Control Bits

The preferred transmission repetition rate is 100ms (can also be sent as required by the application).

### 6.2.2 Control PDO entries

The Object Dictionary entries mapped to the RPDO are:

Index	0x2100
Name	Target Position
Object Type	VAR
Data Type	UNSIGNED16
Description	The target position for the next actuator motion. The 0.0 mm and full extend stroke values represent 0 to 100% stroke and are only relative to the actual available stroke of the individual unit. Resolution: 0.1 mm/bit, 0 offset.

Index	0x2101
Name	Current Limit
Object Type	VAR
Data Type	UNSIGNED16
Description	The current at which the actuator will cease all motion. In the event a force is applied to the actuator that causes the motor current to exceed this settable value for more than 8 ms, the actuator will stop any current motion and activate a dynamic braking effect on the motor. This current limit does not apply during the motor starting phase where in rush current can be significantly higher than normal running. Range: 0.0 A to 8.0 A (12 Vdc actuator), 0.0 A to 4.0 A (24 Vdc actuator), 0.0 A to 2.0 A (48 Vdc actuator). Resolution: 0.1 A/bit, 0 offset

Index	0x2102
Name	Target Speed
Object Type	VAR
Data Type	UNSIGNED16
Description	Controls the PWM driver within the actuator and the voltage applied to the motor. The resultant actuator speed will be a ratio of the actuators max speed, and also dependent on the load applied to the actuator. Range: 20% to 100% duty cycle. Resolution: 0.1%/bit, 0 offset.

Index	0x2103
Name	Movement Profile
Object Type	VAR
Data Type	UNSIGNED8
Description	Controls the behavior of the actuator when trying to reach the target position. Value set to 0: Normal operation, the actuator will run towards the target position at the target speed. It will stop when the target position is reached. This should be the preferred value for most application. Value set to 1: Precise operation, the actuator will perform an extra move after the target position is reached, this will increase accuracy in some applications. Value set to 2: Small step operation, the actuator will run with reduced speed towards the target position. This will allow proper movement during very small positional increments.

Index	0x2104
Name	Control bits
Object Type	VAR
Data Type	UNSIGNED8
Description	Bit 0 (LSB) – Enable bit: This bit is used to enable motion from the actuator. If it is low (0), no motion will be allowed. This bit can be used to define the next actuator movement message without starting the motor. When movement is required this bit can be changed to high (1) and motion will begin using the values of the other objects contained in the RPDO.

### 6.2.3 Control PDO example

Sending a CAN message with ID 0x21B containing the data 0xE8 0x03 0x50 0x00 0x20 0x03 0x00 0x01 will make an actuator to move to position 100mm, at 80% duty cycle, with the current limit set to 12.5A. The example will work on an actuator with the default Node ID, if it is in the operational NMT state.

## 6.3 Actuator feedback

### 6.3.1 Feedback PDO properties

Operational feedback of the actuator is achieved by receiving the statically mapped TPDO with COB-ID 0x180 + Node ID. It will have the following layout:

Byte 0	Byte 1	Byte 2	Byte 3	Byte 4	Byte 5	Byte 6	Byte 7
Measured Position		Measured Limit		Measured Speed		Motion Flags	Error Flags

### 6.3.2 Feedback PDO entries

The Object Dictionary entries mapped to the TPDO are:

Index	0x2200
Name	Measured Position
Object Type	VAR
Data Type	UNSIGNED16
Description	The measured position of the actuator. The 0.0 mm and ordered full extend stroke values represent 0 to 100% stroke but the signaled value does not take in to account any mechanical tolerances or play in the actuator. Resolution: 0.1mm/bit, 0 offset.

Index	0x2201
Name	Measured Current
Object Type	VAR
Data Type	UNSIGNED16
Description	The actual current being used by the actuator. Resolution: 0.1 A/bit, 0 offset

Index	0x2202
Name	Measured Speed
Object Type	VAR
Data Type	UNSIGNED16
Description	The actual duty cycle being applied to the motor through the internal actuator controller. Resolution: 0.1%/bit, 0 offset.

Index	0x2203
Name	Motion Flags
Object Type	VAR
Data Type	UNSIGNED8
Description	Contains information about the current actuator motion. Bit 0 (LSB) – Extending: 1 if currently extending, 0 otherwise. Bit 1 – Retracting: 1 if currently retracting, 0 otherwise.

Index	0x2204
Name	Error Flags
Object Type	VAR
Data Type	UNSIGNED8
Description	<p>Contains information about actuator errors.</p> <p>Bit 0 (LSB) - Parameter Error: This flag is used to inform the user that one of the object values in the RPDO is outside the allowed ranges the specific model will allow. To prevent damage to the actuator motion is not allowed after this flag is set.</p> <p>Bit 1 – Current Overload: This flag is used to inform the user that the last motion the actuator attempted caused an overload condition. This occurs when the actuator determines the current set in the Current Limit object from the RPDO is exceeded for a consecutive 8 ms. When this flag is set by the actuator the user must reset the Motion Enable bit in the RPDO before attempting additional motion from the actuator.</p> <p>Bit 2 – Voltage Error: This flag is used to inform the user that the operational voltage is outside of allowable running parameters. Any motion already in progress will continue for 10 seconds, but additional movement request will not be allowed until the operational voltage returns within the normal operating range.</p> <p>Bit 3- Temperature Error: This flag is used to inform the user that the operational temperature is outside of allowable running parameters. Any motion already in progress will continue for 10 seconds, but additional movement request will not be allowed until the operational temperature returns within the normal operating range.</p> <p>Bit 4 – Backdrive Detected: This flag is used to inform the user that the actuator has determined positional movement in the extension tube that was not commanded from the user. This can be caused from excessive static load or vibration being applied to the actuator.</p> <p>Bit 5 – Message Timeout: This flag is used to inform the user that no RPDO has been received within the time specified in the PDO timeout time object(0x2005). When this flag is set by the actuator the user must reset the Motion Enable bit in the RPDO before attempting additional motion from the actuator. The default value is 5000ms.</p> <p>Bit 6 – Fatal Error: This flag is used to inform the user that the actuator was unable to detect any motion while trying to run the motor, or that the position was updating in the wrong direction. When this flag is set by the actuator the user must reset the Motion Enable bit in the RPDO before attempting additional motion from the actuator. Repeated activation of this flag indicates problems with the actuator, and it is recommended to contact the factory for additional support.</p> <p>Bit 7(MSB)- Memory Error: This flag is used to inform the user that the internal memory of the actuator is corrupted.</p>

## 7. Troubleshooting

### 7.1 Troubleshooting

Troubleshooting list		
Issue	Problem	Solution
Actuator does not move, makes no sound.	Actuator is not receiving proper input voltage.	Ensure the actuator is being supplied with proper rated input voltage.
Actuator makes buzzing sound, does not move.	Actuator does not have enough power and is stalled.	Ensure your power supply can provide enough current to move the rated load.
Actuator moves slower/faster than expected.	Actuator is receiving too low/ too high input voltage.	Ensure that actuator is provided with proper nominal input voltage amount (i.e. 12 Vdc for a 12 Vdc rated actuator).
The actuator, when powered, is causing my fuse to blow.	Fuse is not rated for current draw of the actuator.	Make sure that the fuse is rated for the in-rush current of the actuator, which is typically 1.5 times the rated current draw of the actuator at full load. Slow-blow fuses are also recommended.
The actuator is not stopping at the right place.	Actuator is coasting due to helping load/lack of dynamic braking.	Consider shorting the motor leads together when stopping the actuator to dynamically brake the motor, especially in circumstances where the load applied would "help" move the extension tube.
Actuator is sending a "fatal error" message.	The actuator has encountered an uncommanded change in the stroke feedback device (potentiometer).	The user can reset the actuator first to try and clear the error, but if that does not work, then the actuator will need to be analyzed as an RMA (Return Material Authorization) at the manufacturing facility.
My actuator is not responding to any of the messages I send.	The actuator may have fallen asleep.	The sleep functionality of Electrak MD will engage after 5 seconds of bus inactivity. Send messages to the actuator every 100 ms - 2 s to avoid this from happening. If it has already happened, a "safe state" message will first have to be sent to "wake up" the actuator before it can interpret any other messages.
I am getting an erroneous Overload Flag with no load or current draw on my CNO actuator. How do I fix this?	The actuator control message PGN was set up incorrectly.	<p>"The proper command message should be 18EF2700, where 0x27 is the address of the actuator (default). Keep in mind that if the customer changes the address of the actuator with the physical addressing leads, then the command message will change as well. The address of the CAN controller should be set as something different than the actuator to prevent errors.</p> <p>If an ELS error (C2 on the feedback message) is encountered and the PGN is addressed correctly, simply reset the bus by sending a command message with the enable bit off, then another with it on."</p>

## 8. Technical specifications

### 8.1 Technical data

Technical Specification		MD		
		12	24	48
Input voltage	[VDC]	12	24	48
Input voltage tolerance	[VDC]	9 - 16	18 - 32	36 - 60
Stroke length	[mm]	see product label		
Static load (Fx), maximum	[N (lbs)]	max. static load = max. dynamic load		
Dynamic load (Fx), maximum	[N]	see product label		
Speed, no load / max. rated load	[mm/s (inch/s)]	52/43.8 (2.04/1.72) 28/18.5 (1.10/0.73) 14.5/11 (0.57/0.43) 7/5.4 (0.28/0.21)		
MDxxA025				
MDxxA050				
MDxxA100				
MDxxA200				
Current draw @ rated max. load	[A]	see product label		
Weight	[kg (lbs)]	see table below		
End play, maximum	[mm (in)]	1.2 (0.047)		
Operating temperature limits, standard units	[°C (°F)]	- 40 to + 85 (- 40 to + 185)		
Full load duty cycle @ 25 °C	[%]	see product label		
Restraining torque	[Nm (lbf-in)]	0 (internally restrained)		
Motor leads cross section	[mm <sup>2</sup> (AWG)]	0.75 (18)		
Signal leads cross section	[mm <sup>2</sup> (AWG)]	0.35 (22)		
Cable length (depending on option)	[m (in)]	0.3 (11.8), 1 (39.4)		
Protection class - static		IP67 / IP69K		
Protection class - dynamic		IP66		
Safety features		no (self-locking)		
static load holding brake		yes		
internal end-of-stroke limit switches		no / yes		
overload protection, control options Xxx / Exx, Lxx, CNO, COO		no / yes		
temperature monitoring, control options Xxx, CNO, COO / Exx, Lxx		no / yes		
temperature compensation, control options Xxx / CNO, COO, Exx, Lxx		no / yes		
voltage monitoring, , control options Xxx / CNO, COO, Exx, Lxx		no / yes		
Compliances		CE, ISO 13766		

Actuator Weight [kg (lb)]					
Stroke (see product label) [mm]					
50	100	150	200	250	300
1.1 (2.4)	1.2 (2.6)	1.3 (2.8)	1.4 (3.1)	1.5 (3.3)	1.6 (3.5)

## 8.2 Ordering key

Ordering Key									
Position	1	2	3	4	5	6	7	8	9
Example	<b>MD12</b>	<b>A025-</b>	<b>0300</b>	<b>XXX</b>	<b>2</b>	<b>N</b>	<b>N</b>	<b>S</b>	<b>D</b>
<p>1. Actuator type and supply voltage            MD12 = Electrak MD, 12 Vdc            MD24 = Electrak MD, 24 Vdc            MD48 = Electrak MD, 48 Vdc</p> <p>2. Screw type, dynamic load capacity            A025- = acme screw, 250 N (56 lbs)            A050- = acme screw, 500 N (112 lbs)            A100- = acme screw, 1000 N (225 lbs)            A200- = acme screw, 2000 N (450 lbs)</p> <p>3. Ordering stroke length            0050 = 50 mm            0100 = 100 mm            0150 = 150 mm            0200 = 200 mm            0250 = 250 mm            0300 = 300 mm</p>					<p>4. Electrak Modular Control System options            XXX = internal end-of-stroke limit switches            XXP = XXX + analog (potentiometer) position output            EXX = Electronic Monitoring Package <sup>(1)</sup>            EXP = EXX + analog (potentiometer) position output <sup>(1)</sup>            LXX = EXX + low-level signal motor switching            LLX = LXX + end-of-stroke indication outputs            LXP = LXX + analog (potentiometer) position output            LLP = LXP + end-of-stroke indication outputs            CNO = EXX + J1939 CAN bus + open-loop speed control            COO = EXX + CANopen bus + open-loop speed control</p> <p>5. Harness option            1 = 0.3 m long cable with flying leads            2 = 1 m long cable with flying leads</p> <p>6. Rear adapter/mounting flange options            N = forked cross hole for 10 mm pin</p> <p>7. Front adapter options            N = forked cross hole for 10 mm pin</p> <p>8. Adapter orientation            S = standard            M = 90 ° turned</p> <p>9. Connection options            D = flying leads</p> <p>(1) Option not available for MD48 models (48 Vdc supply voltage).</p>				

Contact us or any of our 2000+ global distribution partners by scanning the code below  
or visiting [www.thomsonlinear.com/contact](http://www.thomsonlinear.com/contact)



**RegalRexnord™**

[www.regalrexnord.com](http://www.regalrexnord.com)

[www.thomsonlinear.com](http://www.thomsonlinear.com)

Electrak\_MD\_Installation\_Operation\_MNUK-0009-04 | 20260122KB  
Specifications are subject to change without notice. It is the responsibility of the product user to determine the suitability of this product for a specific application. All trademarks property of their respective owners. ©2026 Thomson Industries, Inc. | 2400 Curtiss Street, Downers Grove, IL 60515 USA

** THOMSON®**